



PROCEDURE

101.01

Short circuit impedance on transformers with MIDAS 288X

Purpose	Requested equipments	Standard
<ul style="list-style-type: none"> Measurement of short circuit impedance on power transformers at reduced current using the MIDAS 	<ul style="list-style-type: none"> MIDAS 288X 5287 Current Booster 	IEC60076-1 (2000) clause 10.1 IEC60076-1 (2000) clause 10.4 IEC60076-5 (2000) clause 3 & 4 IEC60076-8 (1997) clause 10 IEEE Std C57.12.90-1999 clause 9
		References
		<ul style="list-style-type: none"> MIDAS 288X Instruction manual

The short-circuit impedance ($Z_{short-circuit}$) is defined as the impedance corresponding to the voltage (U_{cc}) that must be connected to one pair of terminals of a transformer, with terminals of other side shorted, which causes rated current (I_{rated}) to flow on the two sides of the transformer.

$$Z_{shortcircuit} = \frac{U_{cc}}{I_{rated}}$$

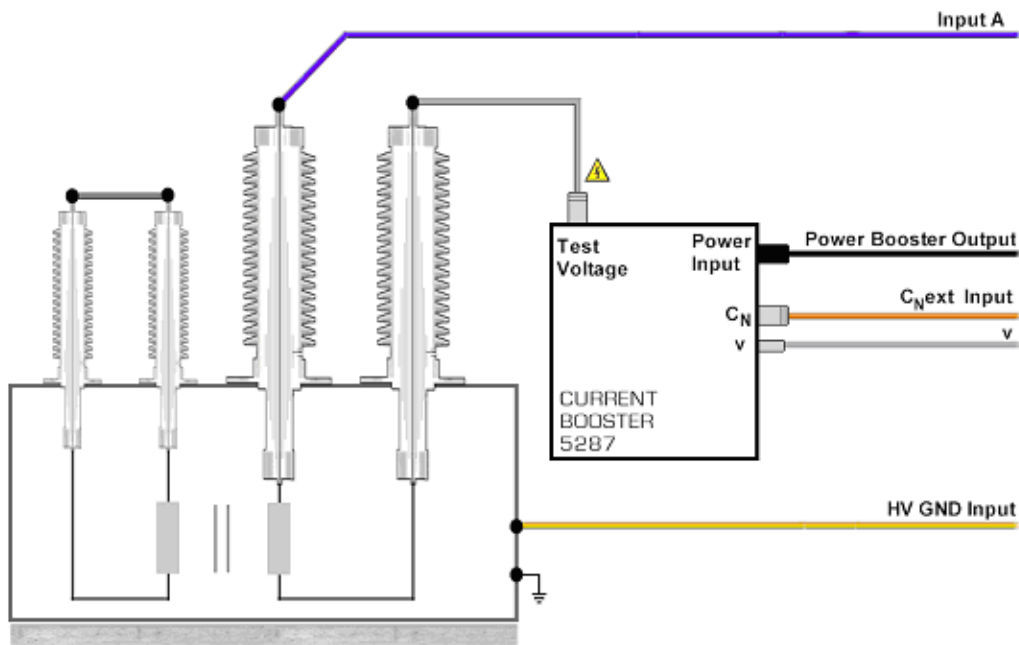
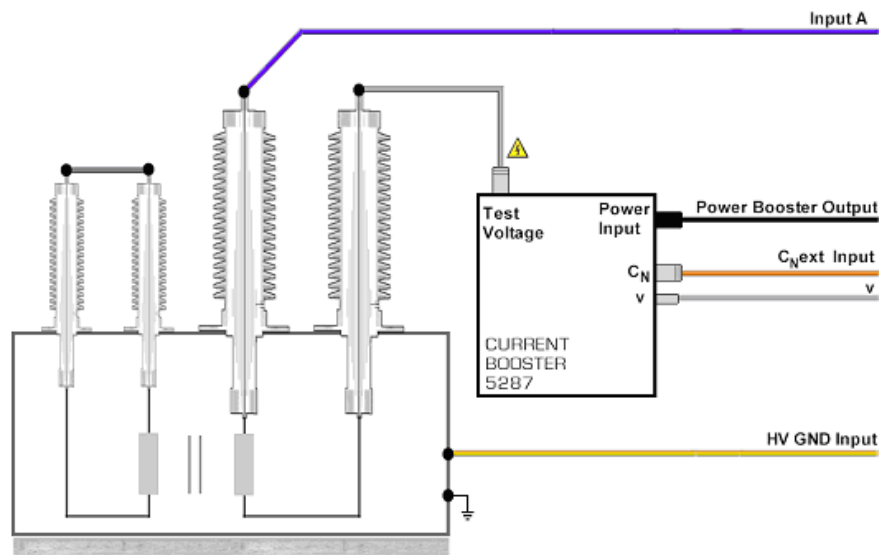

Fig 1. Short-Circuit connection diagram for Midas with current booster 5287

In order to perform this measurement a “Current Booster 5287” in combination with the “MIDAS 288X” is required. The current booster is an additional device connected to the MIDAS power output and provides an output current up to 10A (15A intermitted) at low voltage (10V or 100V). The test connection for measuring short-circuit impedance is outlined below.

Measurement procedure for one phase transformers

1. Connect the current booster to the MIDAS as shown below; short circuit the LV terminals of the transformer and connect the booster and measurement channel A to the HV terminals.



Current, as high as the rated current can flow through the short circuit connection on the LV terminals. Appropriately sized connections must be used, i.e. copper bars on the LV-terminals that can withstand the current.

2. For one phase transformers connection diagram is as following

Measured Variable	High Current to	INPUT A to	INPUT B to	HV GND INPUT to	Test Mode
Z_m	HV Terminal 1	HV terminal 2	-	Tank GND	UST A

After measuring the impedance Z_m the following formula has to be applied:

$$\epsilon_{cc} = Z_m \cdot \frac{S}{U^2} \cdot 100$$

$$u_{cc} = \epsilon_{cc} \cdot U_r$$

Where:

- ϵ_{cc} Short circuit impedance in %
- U_{cc} Short circuit voltage in V
- S_r apparent power in VA from nameplate
- U_r line to line voltage in V from nameplate



Measurement Procedure for three phase transformers

1. For a **three phase transformer** the connection diagram is as follows:

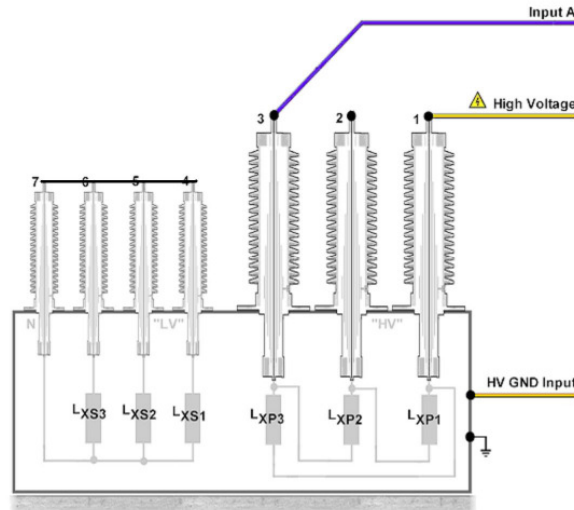

Current, as high as the rated current can flow through the short circuit connection on the LV terminals. Appropriately sized connections must be used, i.e. copper bars on the LV-terminals that can withstand the current.

2. Test connections for three phase transformers with delta and star connections:

Measured Variable	High Current to	INPUT A to	INPUT B to	HV GND INPUT to	Test Mode
Z_{m12} (Lxp1)	1	2	-	Tank GND	UST A
Z_{m13} (Lxp3)	1	3	-	Tank GND	UST A
Z_{m23} (Lxp2)	2	3	-	Tank GND	UST A

If the transformer has a neutral on the HV-side (Yn on HV-side), do not connect any cables to the neutral, connect between the phases. Measurements between Phase and neutral are also possible, however a different formula has to be applied in order to derive the correct (%) short-circuit impedance.

If the above mentioned measurement setup is used to calculate load losses the winding resistance measurements and the winding temperature measurement shall be carried out before the actual short-circuit impedance measurements are performed.



If there are built-in current transformers, they must be shorted during the test to avoid saturation of their iron cores and over-voltages at the secondary terminals. The bushing taps must be earthed.

The duration of the test should be kept as short as possible to avoid any significant heating of the windings. As a rule of thumb a duration of 30 seconds is recommended.

Select in the Software at least U rms (standard), I_{eff} Test and Z_x parameters to be displayed and reported:



3. Switch on the output voltage/current and slowly increase the voltage/current until the current reaches the desired level, make sure that the current stays below the rated current of the transformer.



According to the International Standards; The measurement current should be as close as possible to the rated current. However as a general practice within companies; mostly a fixed value for current is applied to all transformers, in order to have a fixed reference basis.



Overheating of the transformer may occur if the tests are performed with a current higher than the rated current of the transformer or if the test is being performed for too long.

- After measuring the three impedances Z_{m12} , Z_{m13} and Z_{m23} , the following formula has to be applied; in order to obtain the short circuit impedance in %.

$$\epsilon_{cc} = \frac{1}{6}(Z_{m12} + Z_{m13} + Z_{m23}) \cdot \frac{S}{U^2} \cdot 100$$

$$u_{cc} = \epsilon_{cc} \cdot U_r$$

Where:

- ϵ_{cc} Short circuit impedance in %
- U_{cc} Short circuit voltage in V
- S_r apparent power in VA from nameplate
- U_r line to line voltage in V from nameplate

- For verifying the test results a second measurement with approx. 10% lower current can be executed. After extrapolation, the two measurements should agree.

Requested scope of supply

- MIDAS 2880 or MIDAS 2881** Mobile Insulating Diagnosis & Analysing System for automatic capacitance, tan δ and power factor measurements.
- 5287 Current Booster** up to 15 A AC for use with MIDAS 288x for testing of inductances, especially for the measurement of short circuit impedances of power transformers



Measuring data interpretation

- The measurements of short-circuit impedance of transformers don't just give information about the stray inductance of the coil itself, percentage changes in inductivity, compared to earlier measurements or manufacturer's specifications, but can also indicate changes in geometry.
- Changes of 2..4% in Zshort-circuit generally mean a change in coil geometry or coil compression. Values between 4..6% or larger indicate damage to the winding.

European Contact

Haefely Test AG
Lehenmattstrasse 353
4052 Basel
Switzerland
☎ + 41 61 373 4111
📠 + 41 61 373 4912
✉ sales@tettex.com

USA Contact

Hipotronics Inc.
1650 Route 22
PO Box 414
Brewster, NY 10509 USA
☎ + 1 845 279 8091
📠 + 1 845 279 2467
✉ sales@hipotronics.com