

Cable Test Terminations KEV Series



Application

KEV series cable test terminations are used for AC testing as well as for partial discharge and tan delta measurements on plastic-insulated medium voltage cables. These cable terminations are oil-insulated. Their main characteristics include easy handling, short cable preparation times and very short set up times; this is of great importance in routine test applications.

The cable ends can be prepared away from the test laboratory and the cables can be easily installed in the terminations.

Under normal conditions, the insulating oil (commercially available mineral oil) used in the cable terminations can be used for several months before it needs to be replaced or filtered.

The KEV series comprises two different types:

- KEV 50 with a rated voltage of 50 kV (Fig. 3) which can be fastened directly to the cable drum.
- KEV 75/100 with a rated voltage of 75/100 kV (Figs. 1 and 2) is mounted on a trolley which is fitted with a container for collecting oil that drips from the cable when it is removed from the termination.

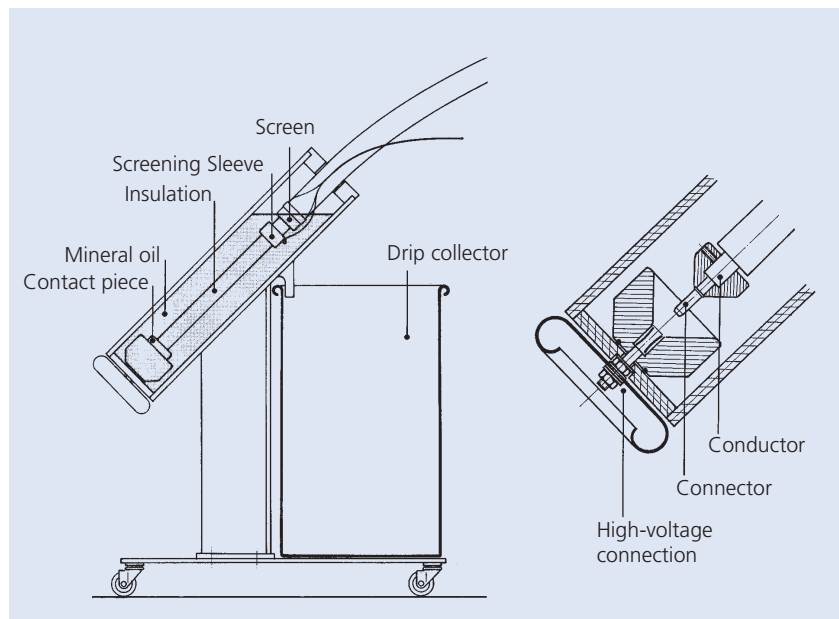

Fig. 2 Cable termination KEV 75

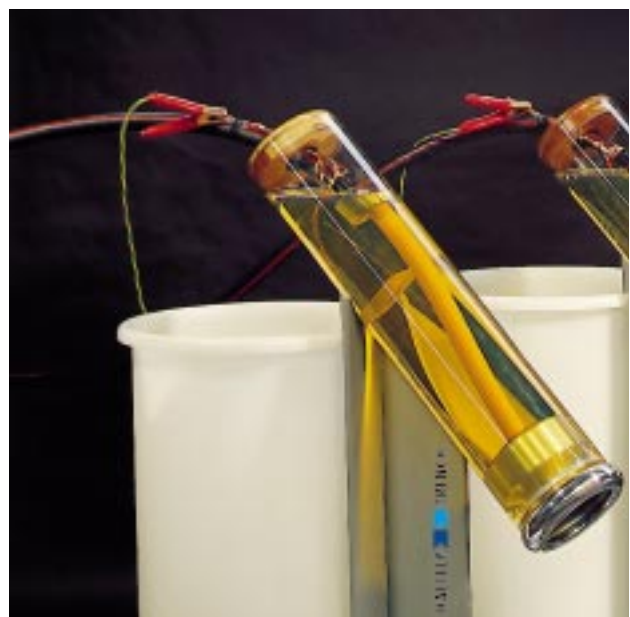

Fig. 1 Cable test termination KEV 75. 75 kV AC

Technical data

	KEV 50	KEV 75	KEV 100
Rated voltage at 50/60 Hz (kV)	50	75	100
PD level at rated voltage (pC)	≤1	≤1	≤1
Test voltage, 50 Hz, 1 min (kV)	60	90	120
Insulation oil volume per termination (l)	2	15	15
Weight (2 units less oil) (kg)	8	45	55
Max. cable diameter over outer semiconducting layer (mm)	35	60	60
Max. conductor diameter (mm)	30	35	35
Length (mm)	660	1090	1200
Height (mm)	595	1360	1380
Width (mm)	220	600	700



Fig. 3
Cable test termination
KEV 50. 50 kV AC

Ordering information code / Scope of delivery

2 cable test terminations 75 kV	KEV 75/ KEV 100	2 cable test terminations 4 screening sleeves 4 contact pieces 2 drip collectors 30 liters insulating oil 1 set of operating instructions
2 cable test terminations 50 kV	KEV 50	2 cable test terminations 4 screening sleeves 4 contact pieces 4 liters insulating oil 1 set of operating instructions
Fastening device KEV50	KEV BEF	2 fastening devices for KEV 50

Subject to change without notice
11.97

E178.72

Trench Switzerland AG
High Voltage Test Division
Lehenmattstrasse 353, P.O. Box
CH-4028 Basel/Switzerland
Phone +41.61.315 51 11
Fax +41.61.315 59 12
www.haefely.com

HAEFELY 
HIGH VOLTAGE TEST