



# DDX 7000 & 8003

## Digital Partial Discharge Detectors

■ **The Hipotronics DDX® Digital Partial Discharge Detector** offers the high accuracy and flexibility of digital technology, plus the real-time display and easy operation of an analog instrument. It is everything you want in a digital system with everything you know from an analog system...truly the best of both worlds.

The DDX® Detector provides the most intuitive and easiest to use operator interface of any available digital PD testing system. Data analysis is fast, easy and requires little training. Its Windows™ based software allows flexible test recording and data export to Word™, Excel™ and other Windows programs. In addition, only the DDX® Detector provides a completely open-architecture hardware and software solution through the use of the fastest processors, Microsoft Windows and Microsoft ActiveX™ technology. Therefore, as additional capabilities are created, they can be easily added to your existing equipment.

The Hipotronics DDX® Detector can also automate your entire PD testing process, from voltage source control to calibration to test report generation.

We offer three different models each aimed at satisfying each customer's specific needs. The Standard DDX® 7000 with robust Partial Discharge analysis software. Next the DDX® 7000 SL with advanced (Automate) partial discharge site location software is geared towards power cable manufacturers where knowing the discharge site is crucial. Finally the DDX® 8003 which offers sophisticated noise suppression technology with the incorporation of additional hardware



---

## FEATURES

- ☑ **Automated Testing** The DDX® Detector can automate your entire PD testing process. Automated calibration simplifies setup. However, when interfaced with other suitably equipped Hipotronics control systems for AC sources, control of the entire HV source is provided through the DDX® Detector and test reports contain complete data on all aspects of the test.
- ☑ **Easy Operation** Ease of use was the mandate to our engineering and design teams. The DDX® Detector uses the worldwide standard Windows™ operating system and an intuitive control and display panel to allow even inexperienced operators to learn quickly with minimal training.
- ☑ **Customized Report Generation** Standard reports cover many QC/QA, process control and product certification needs. The Hipotronics DDX® Detector allows transfer of pulse displays and data into commonly used word processors and spreadsheets such as Microsoft Word™ and Excel™.
- ☑ **Open-Architecture Design** The DDX® Detector has intentionally been designed with an open hardware and software architecture that eliminates obsolescence. Not only is this PD measuring instrument the most advanced instrument available, it will stay the most advanced well into the future.
- ☑ **Advanced Analysis Capability** The DDX® Detector possesses the most flexible analysis tools of any digital partial discharge detector. There is full control over gating of pulses so that the effects of interference can be reduced. Optional software and hardware modules add capability for partial discharge site location, noise suppression, three dimensional plots, calculation of IEC integrated quantities, and discharge pattern fingerprinting.

---

## APPLICATIONS

### Testing of insulation quality in:

- ➔ Power Cables
- ➔ Transformers
- ➔ Bushings
- ➔ Switchgear
- ➔ Circuit Breakers
- ➔ Power Factor Correction Capacitors
- ➔ Lightning Arrestors
- ➔ Universities
- ➔ Laboratories

## DDX 7000

### Digital Partial Discharge Detector

The DDX<sup>®</sup> 7000 offers a full range of standard features which are also included with the DDX<sup>®</sup> 7000 SL and DDX<sup>®</sup> 8003.

#### Automatic Calibration

The DDX<sup>®</sup> detector has a unique, built-in routine that allows calibration to be performed automatically. The automated calibration routine ranges over each amplifier range and calibration pulse setting, this process measures the noises contribution from the amplifier and background. It then automatically adjusts the noise floor to be above the combined noise level. Once automated calibration is completed, the system calculates and displays a noise floor and allows amplifier ranges to be changed without affecting the system calibration in any way. Of course, manual calibration may also be performed using amplifier adjustment to a specified pC/cm

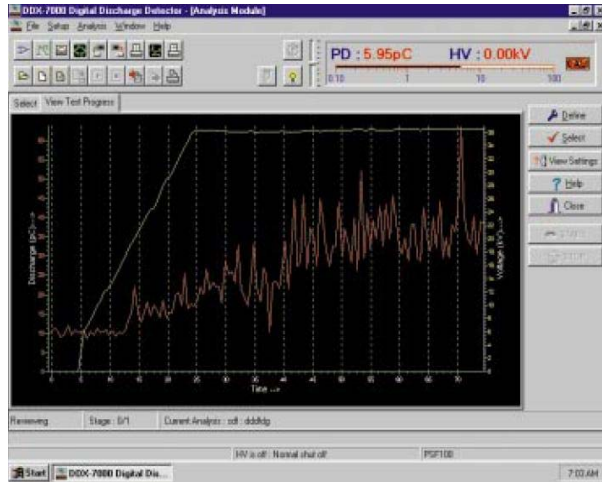
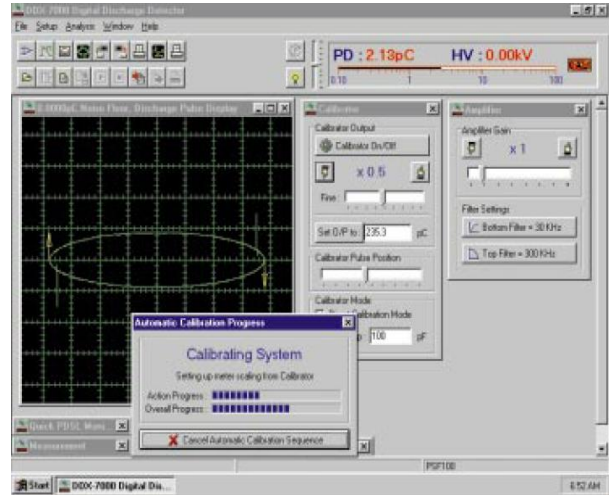

#### Standard Analysis Mode

This flexible software module displays PD in real-time against voltage and time. The software allows review of PD during any time period while the test is in process. Test results may be stored or printed out as necessary. When used with an OT 248 or OT 257 control system control system and HV source, full automatic control of the test sequence can be achieved through the DDX<sup>®</sup> Detector.

#### Pulse Display and Measurement

This flexible software module displays PD in real-time against voltage and time. The software allows review of PD during any time period while the test is in process. Test results may be stored or printed out as necessary. When used with an OT 248 or OT 257 control system and Hipotronics HV source, full automatic control of the test sequence can be achieved through the DDX<sup>®</sup> Detector.

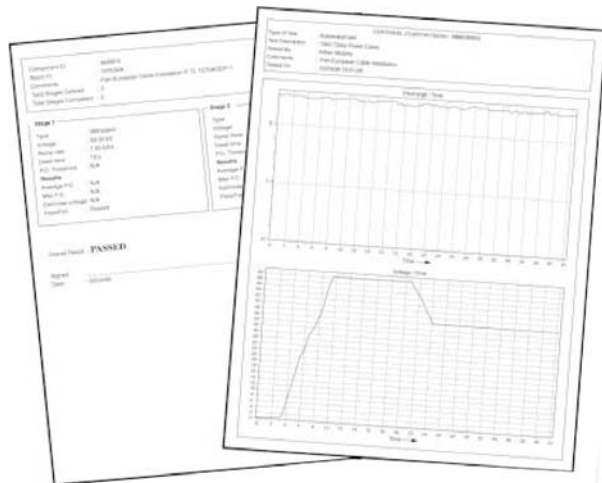
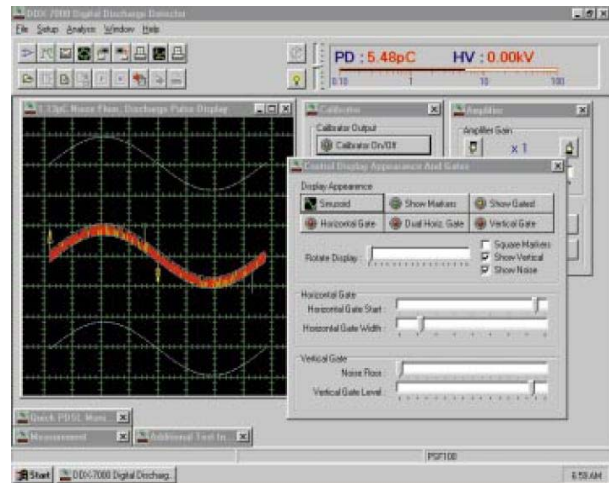

#### Test Reporting

Several standard test records are provided. Data can be inserted into any other Windows application for custom report generation. When used with a Hipotronics AC source and an OT 248 or OT 257 control system, additional data acquisition and control is possible.

## DDX 7000 SL

### Partial Discharge Site Location for Power Cables

Existing international standards require partial discharge measurements on all types of power cables. If partial discharge levels exceed acceptable standards, it is necessary to employ modern, advanced techniques to accurately locate the partial discharge sites so that they can be cut out and the remaining cable shipped to the customer. Older methods of "divide and conquer" (i.e., cutting the cable in half and retesting until the bad section of cable is isolated) wastes time and cable.

Hipotronics patented APDSL Automated and Partial Discharge Site Location Software is a significant advance in PD site location. Not only is it extremely easy to use, but its patented real-time display window and data averaging functions allow an operator to optimize the instrument settings and achieve site location on sites that are less than the pass/fail PD level, near the end of cable. Depending on PD site magnitude and inception voltage, it is also possible to find multiple sites in a reel of cable.

The patents specifically cover the method of display and the rejection of transients and other interference. These new developments make it very easy for an operator to understand the pulse locations and make it possible to operate the system in a less than ideal environment.

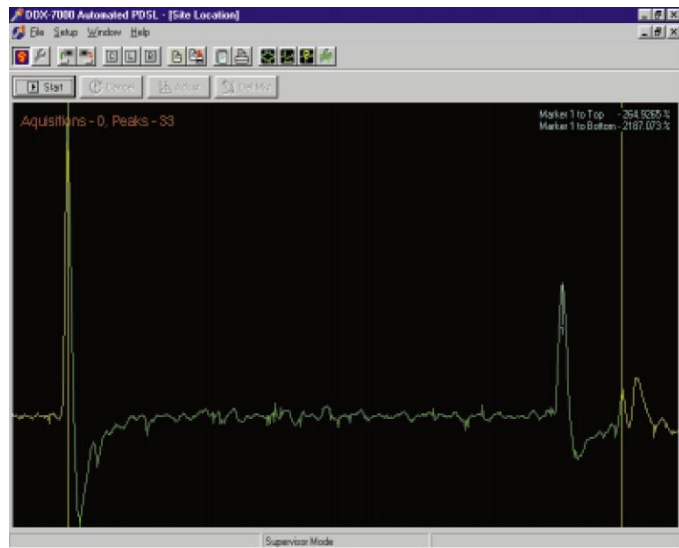

*This 2452 ft cable had PD measuring 12pC in magnitude. This fault was easily detectable by adjusting the trigger level in the PDSL software program to locate lower level faults. Note that in doing so, a small amount of background noise is displayed. The Hipotronics PDSL found the fault 265 feet from the top of the cable. The customer cut around the PD site. The cable was retested and passed. Further analysis by the customer indicated that the fault was located at 265.5 feet, an accuracy of much better than .1%.*

Operation of the system is very easy. The operator enters the length of the cable to be site located, and presses START. The system automatically calibrates itself and allows operator fine adjustment if necessary. The operator applies voltage to the cable until PD inception, at which point the operator collects data. The entire process is completed in a matter of minutes with on-screen verification of the site location from the top and the bottom end of the cable. The entire site location can be completed using the

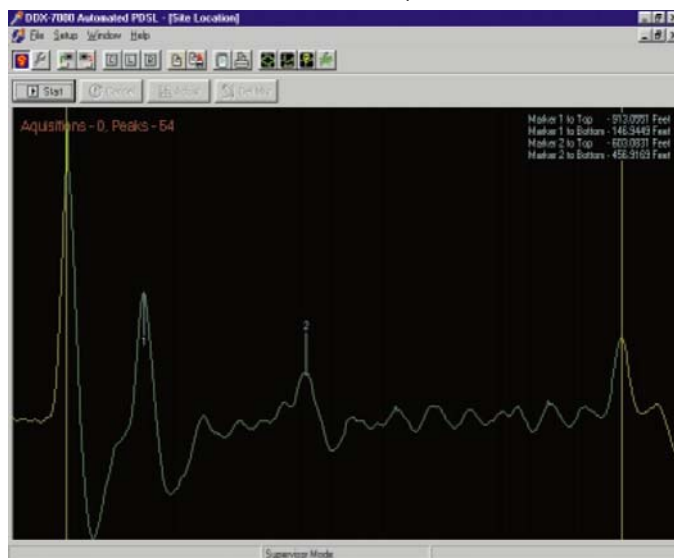

*This 1000', 1000MCM cable had PD measuring 30pC at test voltage. The Hipotronics APDSL found two faults in this cable. The customer later cut the cable as indicated (with an additional 3 feet on either side of the site) and found less than 5pC at full voltage during the PD test.*

same Hipotronics Power Supplies, HV Filters, and other HV test components. No reconnection of hardware is generally required to change from PD magnitude measurement to PD Site Location. In some cases, the operator may be required to change calibration points from one end of the cable to the other to achieve optimum results.

Due to various types of cable constructions, insulating materials, insulation wall thicknesses, background noise levels, etc., it is difficult to quote absolute PD Site Location accuracy; however, experience has shown accuracies in the range of 0.1% for 15kV/220mil wall thickness XLPE "commodity" utility cable. Accuracy can be expected to be somewhat less for cables with higher characteristic impedance.

To measure PD site locations in very short lengths of cable (< 800'/250m), Hipotronics can supply an optional PDSL-CART that changes the inductance of the cable at the termination point, thereby changing the "ringing" frequency of the PD pulse as it travels through the cable.

## DDX 8003

### Pulse Discrimination

In factory tests, electrical interference noise can seriously affect sensitive partial discharge measurements. Traditionally, the method of eliminating this noise has been to screen the test area. In some cases, the use of a screened room limits testing flexibility and impedes the free flow of products during manufacture.

The DDX<sup>®</sup> 8003 Pulse Discrimination PD Detection System electronically rejects interference noise, allowing complete flexibility of testing together with a flow of production.

#### Principles of Operation

There are a number of different ways in which interference noise can enter a partial discharge detection circuit in a typical industrial test environment. Noise can come from conduction through the mains voltage supply, airborne pick-up, and transient coupling. Noise can be caused by pulse interference generated by thyristor controllers, pulse interference from other sources, or continuous radio frequency transmissions. The Pulse Discrimination System will minimize each source and type of noise.

#### Pulse Interference

Three complementary techniques for suppressing unwanted pulse interference are included in the DDX<sup>®</sup> 8003 detector:

##### *Pulse Discrimination*

A source of external interference will introduce a pulse into the circuit that follows the solid path E (External Interference Pulse). This pulse flows through the two measuring input units A and B in the same direction—giving a detected pulse in each that has the same polarity.

The Type 8003 detector receives these two pulses simultaneously and compares their polarities. If the pulse polarities are the same in channels A and B, then the pulse is defined as an external interference. If the two pulses have opposite polarities, then the source of the pulse is defined as within the test circuit, i.e., C<sub>x</sub> or C<sub>b</sub>. The operator can choose to view and measure either all the pulses detected regardless of source, only those pulses that originate within the test circuit, or only those pulses that are external interference.

The Type 8003 is also able to separate those internal pulses that are caused by partial discharges in C<sub>x</sub> from any pulses originating in C<sub>b</sub>, thus allowing two objects to be tested at the same time.

##### *Radio Interference*

Some radio broadcast frequencies may fall within the measuring bandwidth of the detection system, reducing the sensitivity of the partial discharge test. The DDX<sup>®</sup> 8003 includes a radio frequency suppressor to improve operation under such conditions. The 8003 operates on the principal that the radio signals are coupled to the high voltage line and flow to earth through the measuring input units following the path E. The detected radio signals on A and B will be in-phase with each other and an analog subtracter is used to attenuate these signals. In this way, the actual sensitivity of a test can be significantly improved.

##### *Transient Suppression*

The use of the 8003 is applicable when the intermittent pulses of interference are caused by the switching of heavy machinery in close proximity to the test area (such as overhead cranes). The interference, likely to be radiated through the air, can be introduced by the High Voltage test circuit. A simple antenna (measuring unit N) placed close to the test circuit detects any radiated pulses. By selecting this function, the Type 8003 will reject pulses detected at A and B while there is also an interference pulse detected on the antenna channel N.

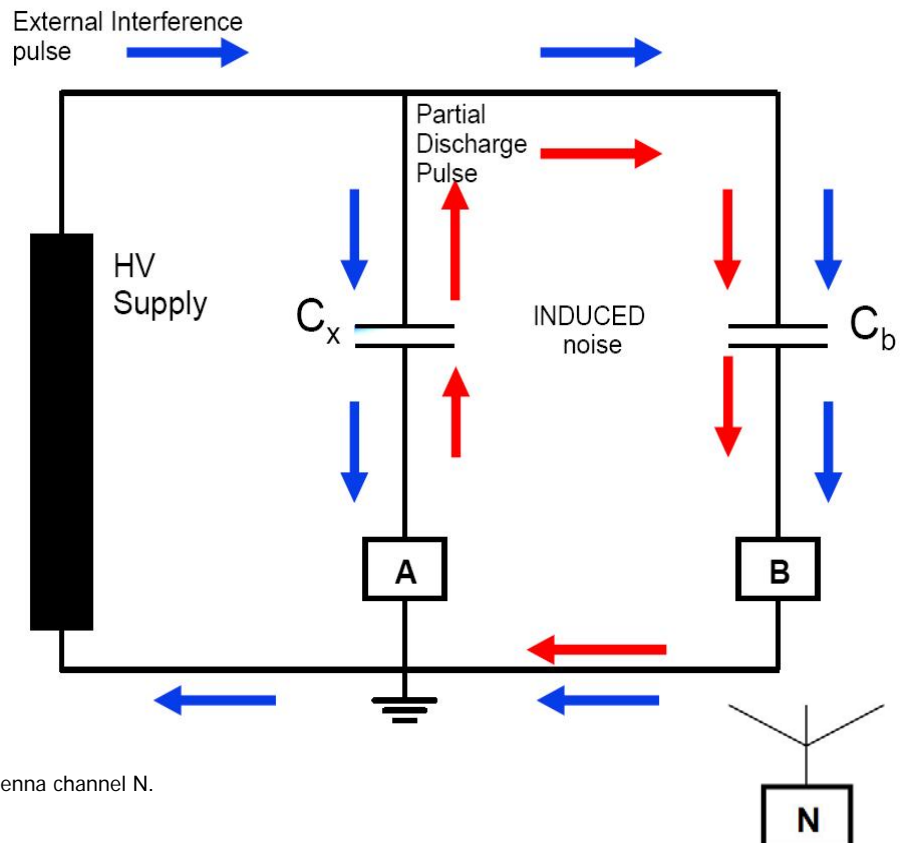

**ADVANCED ANALYSIS SOFTWARE PACKAGE**

**DDX® DA3**

The DDX® DA3 is a powerful, optional software package that is used with the Hipotronics DDX® Partial Discharge Detectors. The DDX® DA3 Software Package is an ideal tool for research and development or evaluation laboratories. It allows a user to collect data on partial discharge activity and display it in several different formats for easy analysis and comparison. Multiple blocks of data can be stored, with the option upon recall of viewing one, several or all of the blocks. Allowable displays include PD Value vs. Phase, PD Value vs. Time, Fingerprint, Intensity, and Fractal Chart.

**PD Value vs. Phase**

Displays the number of PD pulse occurrences, maximum PD magnitude, and average PD magnitude as a function of phase.

**PD Value vs. Time**

Displays maximum and average PD magnitude, power, repetition rate, current, and quadratic rate as a function of time.

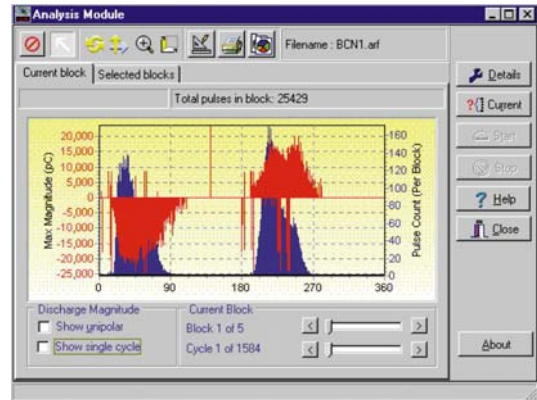

*PD Value vs. Phase*

**Intensity**

Displays the relative intensity of PD pulses as a function of phase and either PD magnitude or energy. The mouse can be used to identify the intensity level of a given point on the chart.

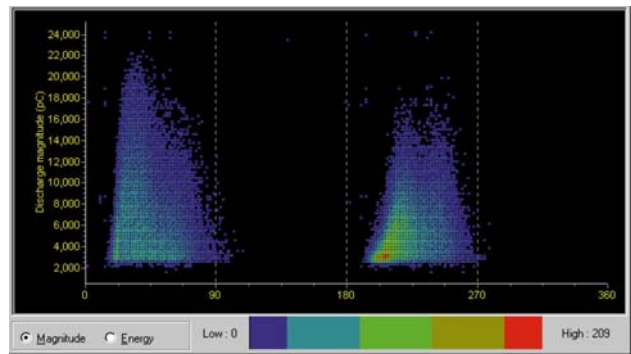

*Intensity*

**Fractal Chart**

An alternative view of the data shown in the intensity chart. The Z axis represents discharge magnitude, the X axis phase, and the Y axis intensity.

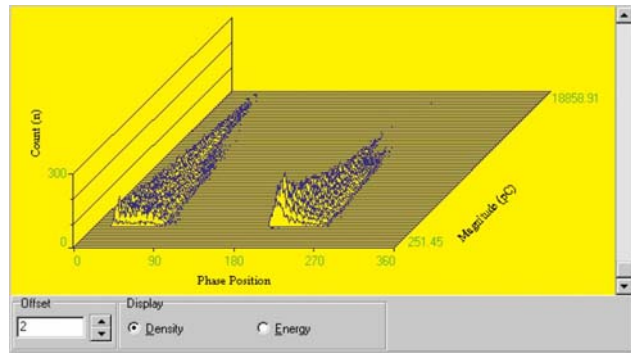

*Fractal Chart*

**Fingerprint**

Displays a collection of 29 statistical operators performed on the PD data, made up skewness, asymmetry, cross correlation, and phase factor. Fingerprint data can be compared to previous test data to determine cause of PD.

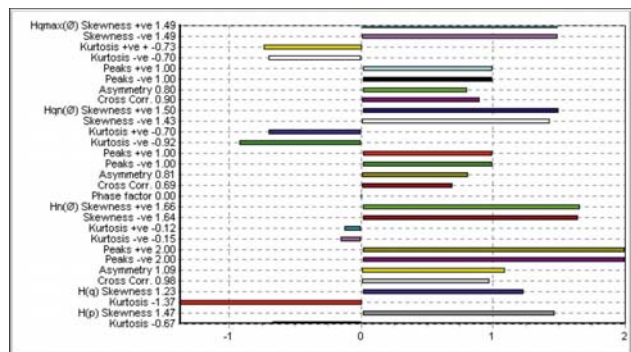

*Fingerprint*

## TECHNICAL SPECIFICATIONS

### Measurement Unit

PD Measurement Range	0 ... 99999pC, in standard notation
PD Measurement Resolution	9 bits plus sign
PD Phase Resolution	0.35 degrees
PD magnitude Display	Analog style bar graph and digital read out
Time Resolution	12.5nS (80 MHz sampling rate)
Capture Memory Depth	256 cycles, 256+ samples
Amplitude Capture Accuracy	Better then 1%
Amplifier Ranges	12 switched 5 dB ranges
Amplifier Frequency Range	20kHz ... 500kHz
Voltage Measurement Range	0 ... 99999kV peak scaled RMS and true RMS
Voltage Measurement Resolution	11 bits plus sign
Voltage Measurement Accuracy	Better then 0.5% at I/P socket
Voltage Frequency Sync Range	5Hz ... 500Hz
Voltage Measurement Input	10V peak
Calibrator Maximum Output	10V step (1000pC into 100pF)
Calibrator Output Range	1mV ... 10V in 13 Ranges
Calibrator Fine adjustment	0 ... range voltage in 256 steps
Calibrator Output Rise Time	Less then 25nS into 100pF, slower for higher capacitances
Calibrator Operating Modes	Direct and indirect (transfer) mode supported
PD Amplifier ranges	6 switched 20dB ranges
PD Amplifier Fine Adjustment	10:1 in 200 steps
PD Amplifier Gain Linearity	<1% over whole range
PD Amplifier Frequency Range	20kHz to 500kHz
PD Amplifier Filter Settings	High Pas: 20kHz, 30kHz, 50kHz, 60kHz, 80kHz Low Pass: 100kHz, 200kHz, 300kHz, 400kHz, 500kHz
Discharge Display	Ellipse, Straight Line, Sine Wave Base, Sine Loop
Discharge Refresh Rate	Up to 25 / second
Synchronization Frequency Range	5Hz – 500Hz
Window Gating	1 or 2 gates on sine wave
Operating Temperature	10°C ... 35°C
Weight and Dimensions	40 or 50Lbs (18 or 23kg) 17.5" x 10.5" x 18" (445mm x 270mm x 460mm)
Interfaces	USB, Ethernet, RS232, Trackball, Keyboard, CD Drive
Data Format	.csv
Display	10.4" LCD
Operating System	Windows XP
Processor	Pentium III or greater
Hard Drive / RAM	≥ 20 Gb / ≥ 512 Mb

### Scope of Supply

#### DDX 7000 & DDX 7000 SL

- 1 DDX unit (including operating system and DDX software)
- 1 Trackball
- 1 Keyboard
- 1 Three channel transient filter
- 1 line cord
- 3 15m BNC coaxial cables (red, green & blue)
- 3 2m BNC coaxial cables (red, green & blue)
- 1 50 Ω terminating resistor
- 1 Isolation Transformer

#### DDX 8003

- 1 DDX unit (including operating system and DDX software)
- 1 Trackball
- 1 Keyboard
- 2 Three channel transient filter
- 1 line cord
- 4 15m BNC coaxial cables (red, green & 2 blue)
- 4 2m BNC coaxial cables (red, green & 2 blue)
- 1 50 Ω terminating resistor
- 1 Isolation Transformer

European Contact  
Haefely Test AG  
Lehenmattstrasse 353  
CH-4028 Basel  
Switzerland  
☎ + 41 61 373 4111  
☎ + 41 61 373 4912  
✉ sales@haefely.com

Locate your local  
sales representative at  
[www.high-voltage-hubbell.com](http://www.high-voltage-hubbell.com)

USA Contact  
Hipotronics Inc.  
1650 Route 22  
PO Box 414  
Brewster, NY 10509 USA  
☎ + 1 845 279 8091  
☎ + 1 845 279 2467  
✉ sales@hipotronics.com